

NL Series



DC/DC

12.5 and 25 Watts

Single Outputs

- 4.5-5.5 Vdc inputs
- Efficiency to 86%
- Regulated output
- Trim adjustable
- Six sided shielding

Specifications

INPUT

Voltage Range 4.5 - 5.5 Vdc

OUTPUT

Voltage Tolerance $\pm 1\%$ (trim adjustable)
Ripple and Noise 50mV pk-pk
20 Mhz bandwidth
Short Circuit Protection Continuous Power Cycle
Trim Adjustability $\pm 10\%$ (typ)
Temperature Coefficient 0.02% / °C

GENERAL

Regulation:
Line 0.5%
Load 1.0% (25%-FL)
Efficiency 86% (typ)
I/O Isolation Not galvanically isolated

ENVIRONMENTAL

Operating Temperature -25°C to +60°C
Max baseplate Temp 105°C
Storage Temperature -40°C to +105°C
Cooling Free-air Convection

All specifications are typical at nominal line and full load at 25°C unless otherwise noted and are subject to change without notice.

The NL Series are highly efficient, single output DC/DC converters. These highly efficient, low cost converters are designed to power the latest microprocessors and low voltage logic. The output of the NL Series can be trim-adjusted by user added circuitry to fine tune for optimum supply voltage

Applications

The NL Series is designed for point of load regulation, space-critical applications, as well as other applications not requiring input-output isolation.



**SEMICONDUCTOR
CIRCUITS, INC.**

888.438.3232 888.GET.DCDC

NL Series Ordering Information

Input Voltage Range	Output Voltage	Output Current	Case	Model Number
4.5-5.5 Vdc	3.3 Vdc	8000mA	A	NL17-800-05A
4.5-5.5 Vdc	3.3 Vdc	8000mA	B	NL17-800-05B
4.5-5.5 Vdc	3.3 Vdc	4000mA	C	NL17-400-05C

Dimensions and Connections

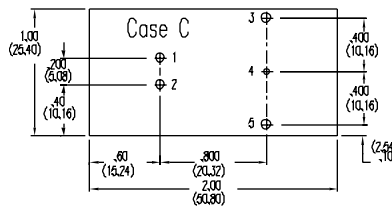
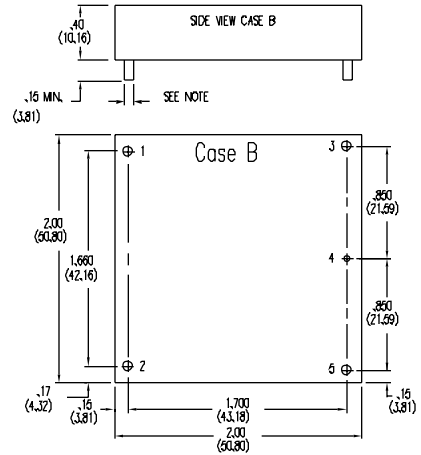
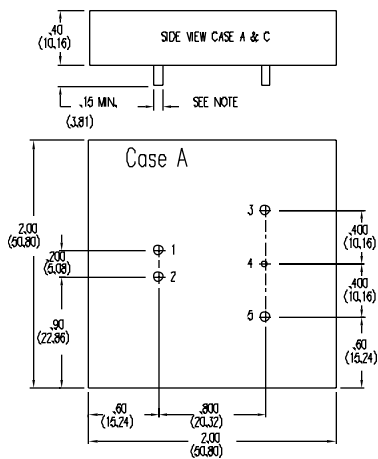

PIN CONNECTIONS

Single Output

1. +Input
2. -Input
3. +Output
4. Trim
5. Common

NOTES:

1. Ripple measured with a 3.3 mf tantalum capacitor across each output.
2. Load regulation from full load to minimum load (25%).
3. External Output Trimming: Output may be externally trimmed $\pm 10\%$.

11/01/2001